



**MCombo®**

BEDIENUNGSANLEITUNG

# SERVICEWAGEN MIT ROLLEN HOLZ & METALLGESTELL

 shopify



Mcombo.de

 amazon



Amazon.de/mcombo

Pfillo GmbH, Kreuzweg 60, 47809 Krefeld, Germany







(9:00am - 16:30pm von Montag bis Freitag)

pfillo.de@gmail.com

**PFILO GmbH:** [www.mcombo.de/pfillo.de@gmail.com](http://www.mcombo.de/pfillo.de@gmail.com)

**6090-0022**

# SICHERHEITSHINWEISE

-  Lesen und befolgen Sie die Informationen im Benutzerhandbuch.
-  Bitte halten Sie Kinder aus Sicherheitsgründen von kleinen Komponenten fern.
-  Das Produkt soll in einer trockenen Umgebung verwendet werden.
-  Bitte beachten Sie, dass Holz nicht kratzfest ist.
-  Wasserflecken und Flecken soll rechtzeitig gereinigt werden.
-  Platzieren Sie keine übergewichtigen Gegenstände.
-  Bitte behandeln Sie Holz und anderes Zubehör sachgemäß.

## — HAFTUNGSAUSSCHLUSS —

Wir bitten Sie, diese Anleitung vollständig zu lesen, bevor Sie Ihr neues Gerät zusammenbauen und in Betrieb nehmen. Wir sind nicht und können nicht für Schäden oder Verletzungen verantwortlich gemacht werden, die durch unsachgemäße oder unsichere Verwendung des Artikels entstehen. Wir lehnen ausdrücklich die Verantwortung für Körperverletzungen oder Sachschäden ab, die bei einer Verwendung auftreten können, die nicht den geltenden Bundes-, Landes- oder lokalen Gesetzen oder Verordnungen entspricht. Bitte bewahren Sie dieses Handbuch für zukünftige Bezugnahme auf.



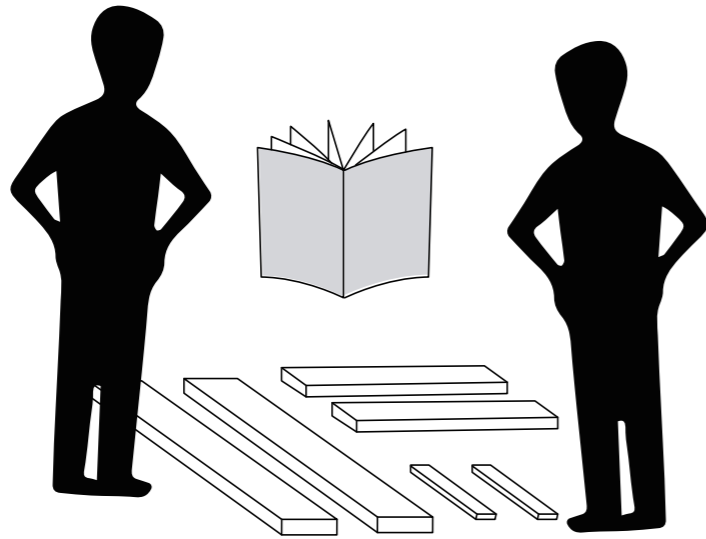



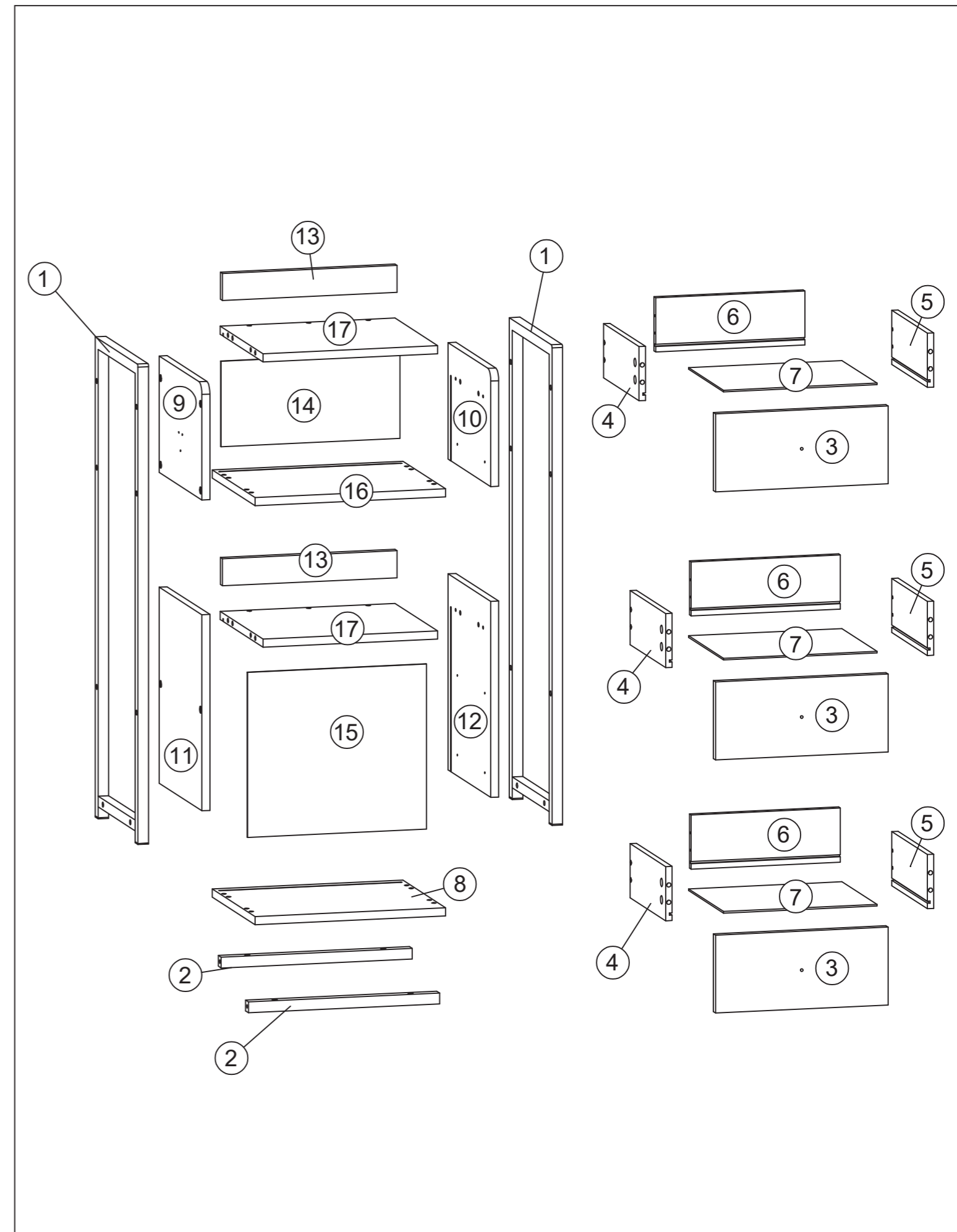



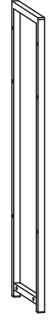

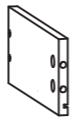



# INSTALLATIONSVORBEREITUNG

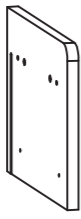











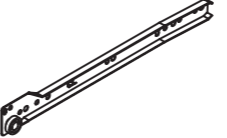
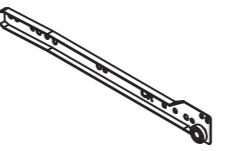
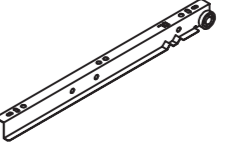
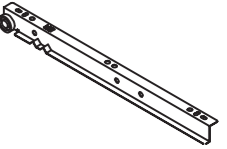
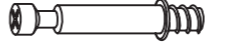



- Bitte bereiten Sie einen Teppich oder eine Matte vor, um Ihren Boden zu schützen. Sie müssen alle Zubehörteile auslegen.
- Bitte bereiten Sie ein Paar Handschuhe vor, um Kratzer durch scharfes Holzsägemehl zu vermeiden, das während der Installation auftreten kann.
- Bitte öffnen Sie alle Kartons, um zu überprüfen, ob das Zubehör vollständig und in gutem Zustand ist.
- Die Box enthält einige kleine Komponenten, bitte platzieren Sie sie vor der Installation richtig, um sie von Kindern fernzuhalten und die Sicherheit zu gewährleisten.
- Wenn Sie Elektrowerkzeuge verwenden müssen, um dieses Produkt zu installieren, stellen Sie bitte die Geschwindigkeit im Voraus auf niedrige Geschwindigkeit ein.
- Richten Sie bei der Installation bitte alle Löcher aus bevor Sie alle Schrauben festziehen.

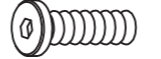
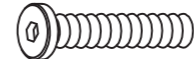
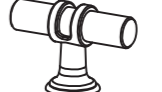

# ZUBEHÖRTEILE

<b>1</b>  x2	<b>2</b>  x2	<b>3</b>  x3	<b>4</b>  x3
<b>5</b>  x3	<b>6</b>  x3	<b>7</b>  x3	<b>8</b>  x1
<b>9</b>  x1	<b>10</b>  x1	<b>11</b>  x1	<b>12</b>  x1
<b>13</b>  x2	<b>14</b>  x1	<b>15</b>  x1	<b>16</b>  x1
<b>17</b>  x2			

# SCHRAUBENGRUPPE

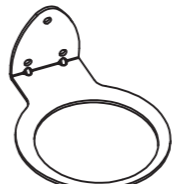
<b>A</b>  250L x3	<b>B</b>  250L x3	<b>C</b>  250L x3	<b>D</b>  250L x3
<b>E</b>  Ø6*35mm x20	<b>F</b>  Ø15*12mm x8	<b>G</b>  Ø15*10mm x12	<b>H</b>  Ø8*30mm x18
<b>I</b>  Ø4*16mm x3	<b>J</b>  Ø7*40mm x12	<b>K</b>  Ø3.5*14mm x32	<b>L</b>  Ø4*35mm x12
<b>M</b>  M6*30mm x16	<b>N</b>  M6*40mm x4	<b>O</b>  x3	<b>P</b>  M4*22mm x3
<b>Q</b>  x8	<b>R</b>  x1	<b>S</b>  4mm x1	<b>T</b>  M8 x1
<b>U</b>  x4	<b>V</b>  x1		

# INSTALLATIONSANLEITUNG

## Schritt 1

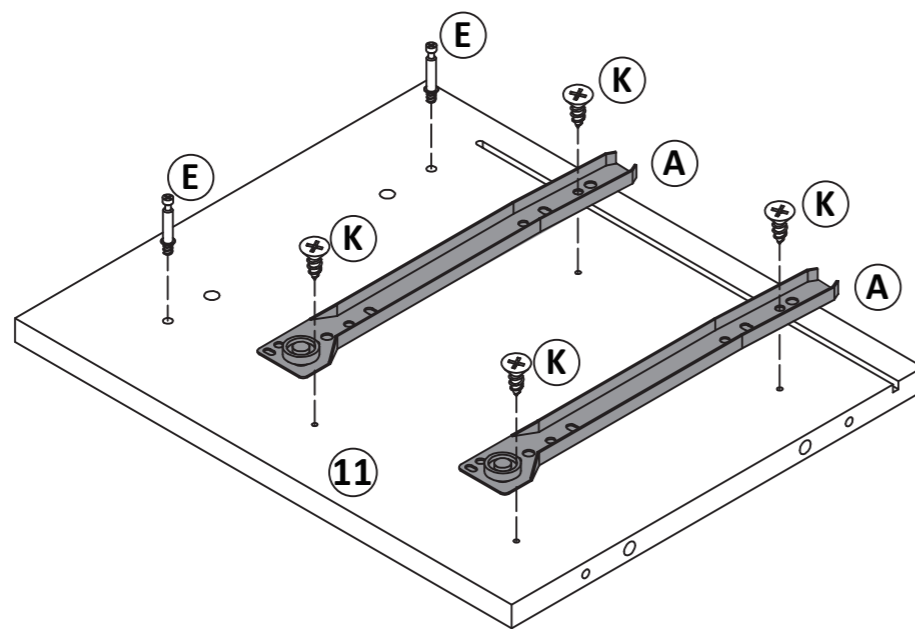
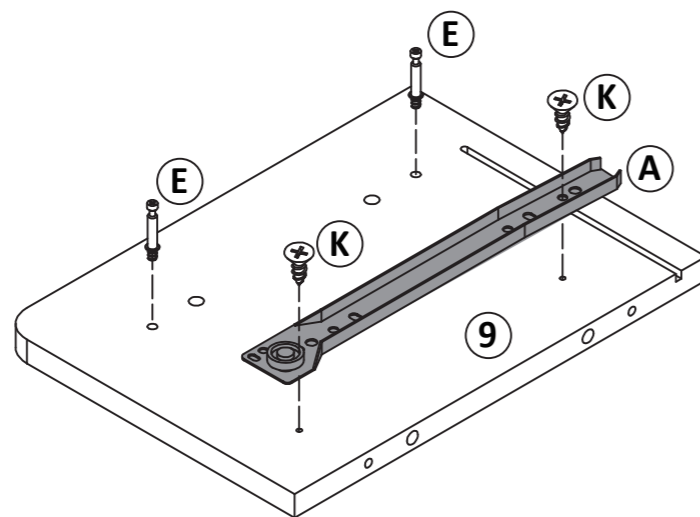
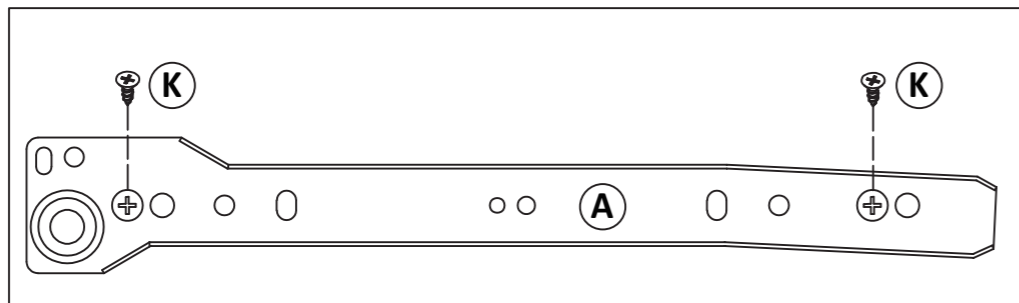

- ⑨ X 1
- ⑪ X 1
- Ⓐ X 3
- Ⓔ X 4
- Ⓚ X 6

# INSTALLATIONSANLEITUNG

## Schritt 2

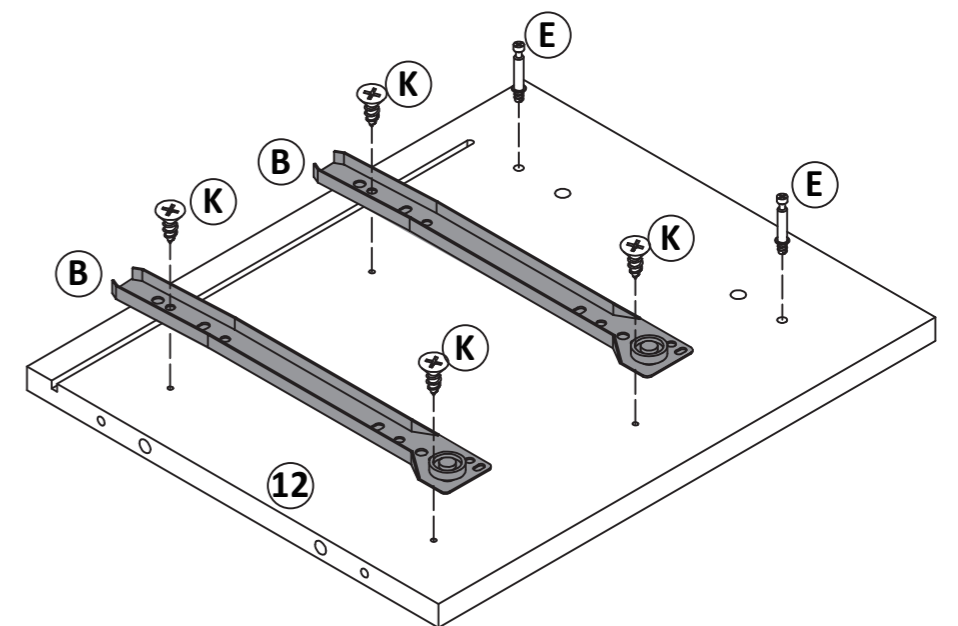
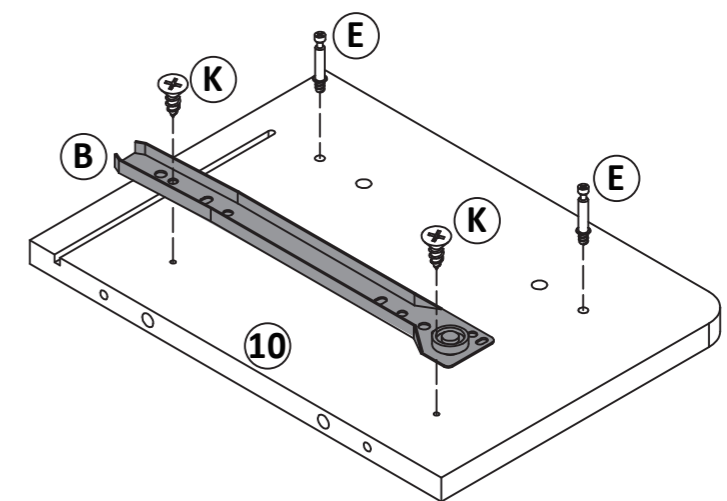
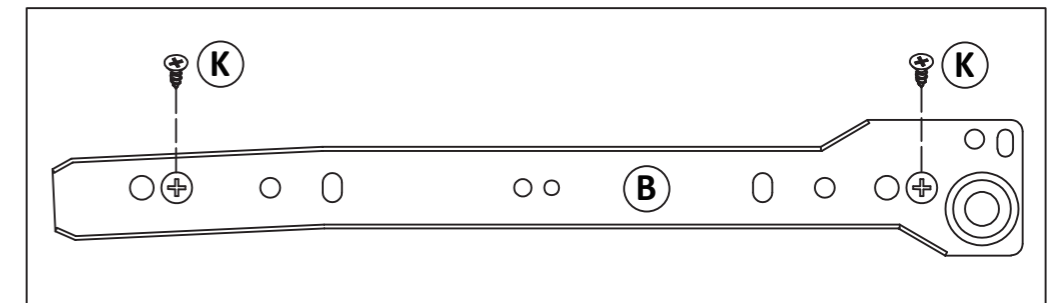

- ⑩ X 1
- ⑫ X 1
- Ⓑ X 3
- Ⓔ X 4
- Ⓚ X 6

# INSTALLATIONSANLEITUNG

## Schritt 3

- ⑬ X 2
- ⑰ X 2
- ⓓ X 2
- ⓙ X 4

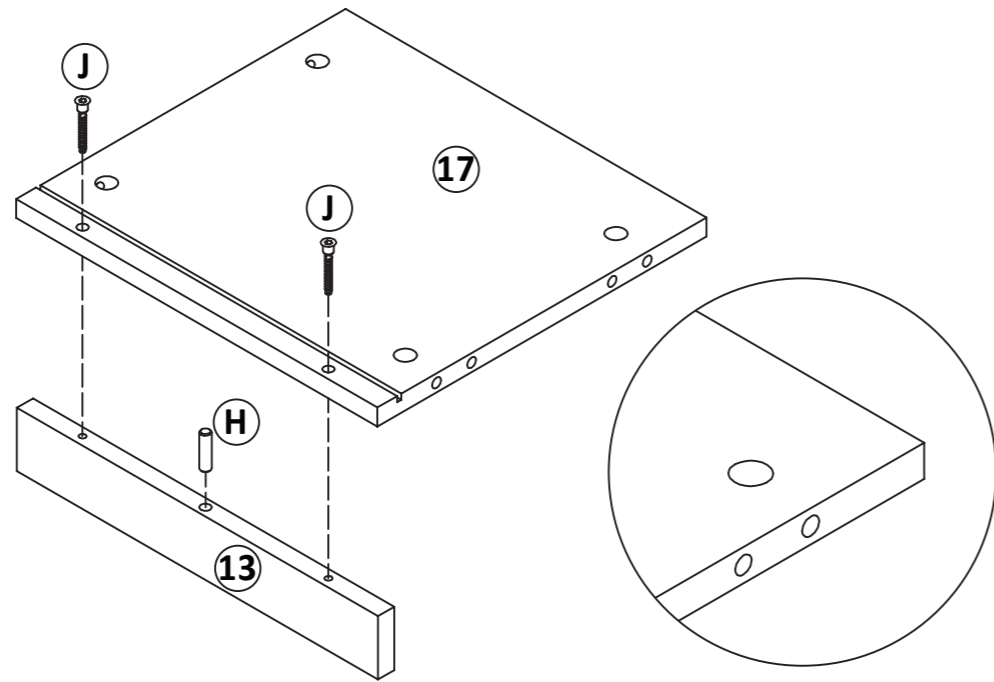

X 2

## Schritt 4

- ⑨ X 1
- ⑩ X 1
- ⓕ X 4
- ⓓ X 4

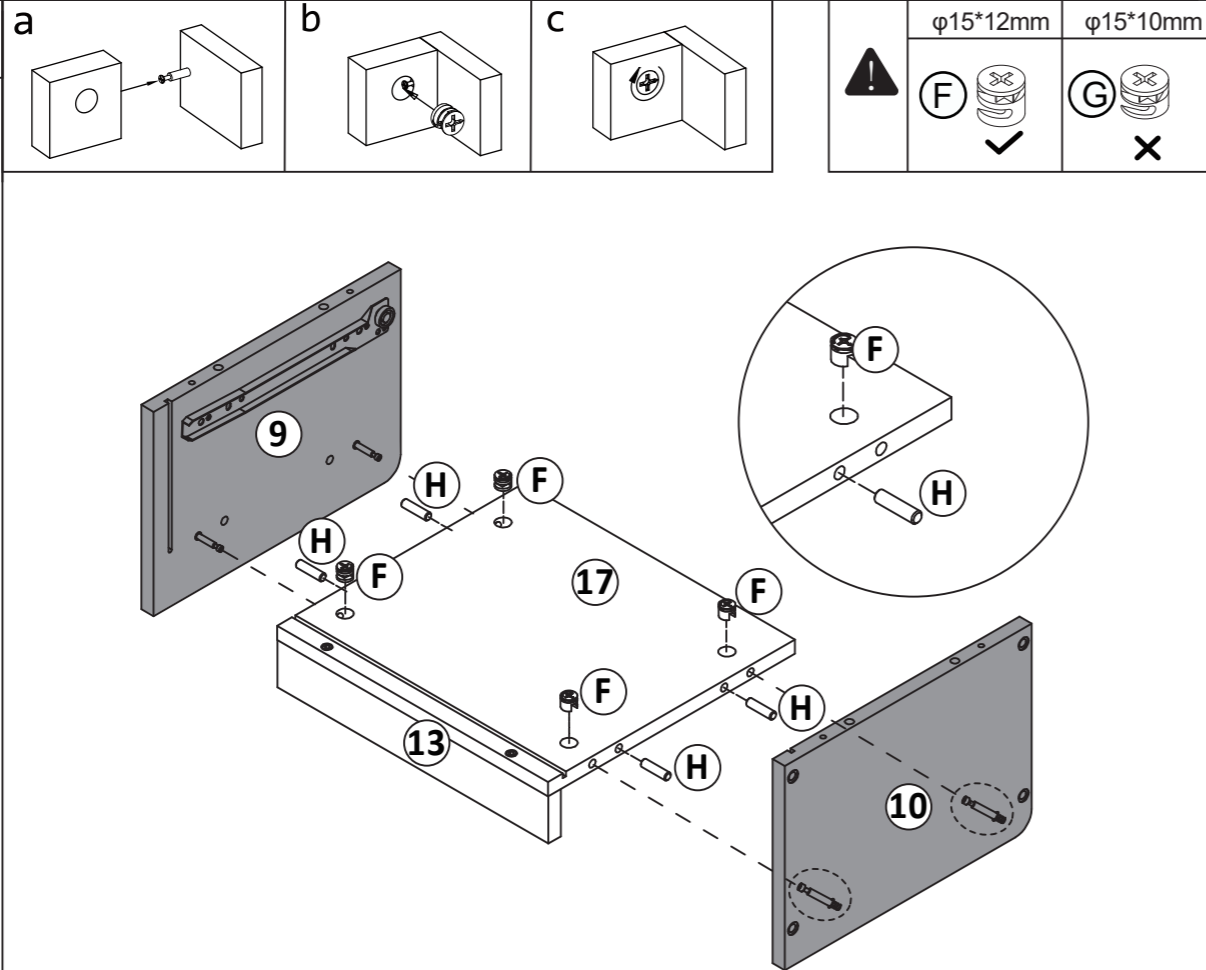

# INSTALLATIONSANLEITUNG

## Schritt 5

- ⑭ X 1

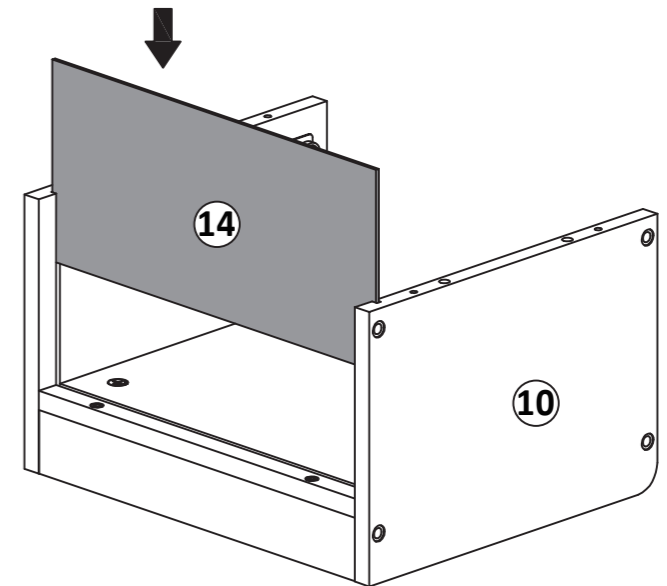

## Schritt 6

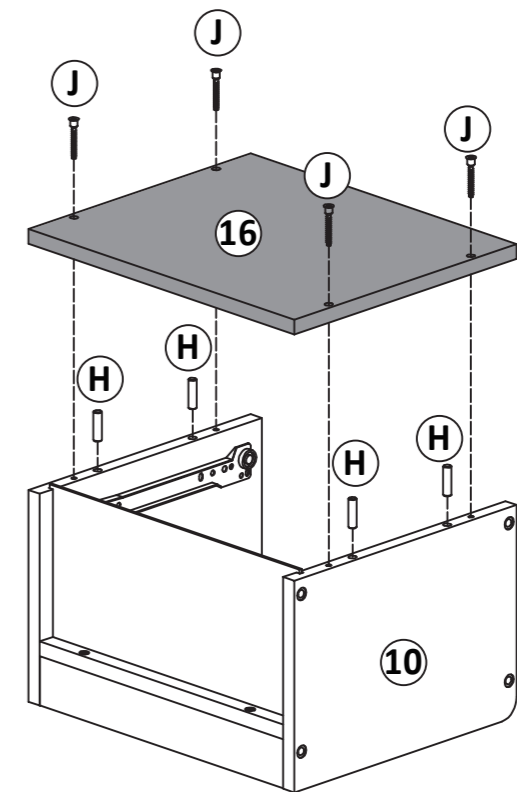

- ⑯ X 1
- ⓓ X 4
- ⓙ X 4

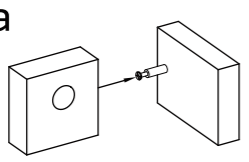
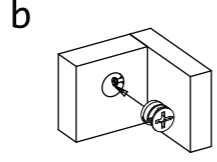
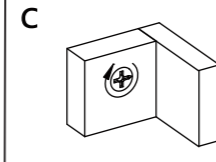

# INSTALLATIONSANLEITUNG

**Schritt 7**

a  b  c 

  

①① X 1  
 ①② X 1  
 ①③ X 4  
 ①④ X 4

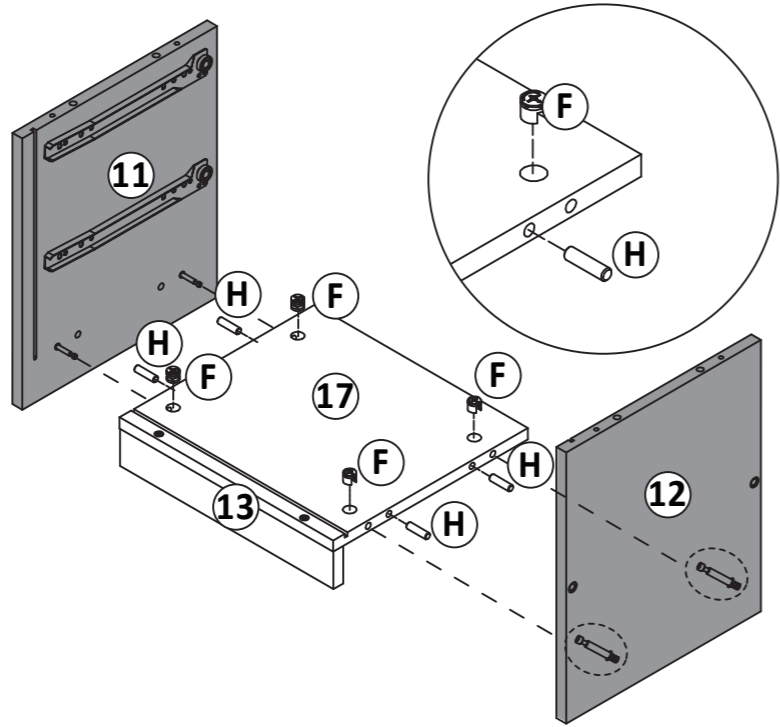

**Schritt 8**

①⑤ X 1

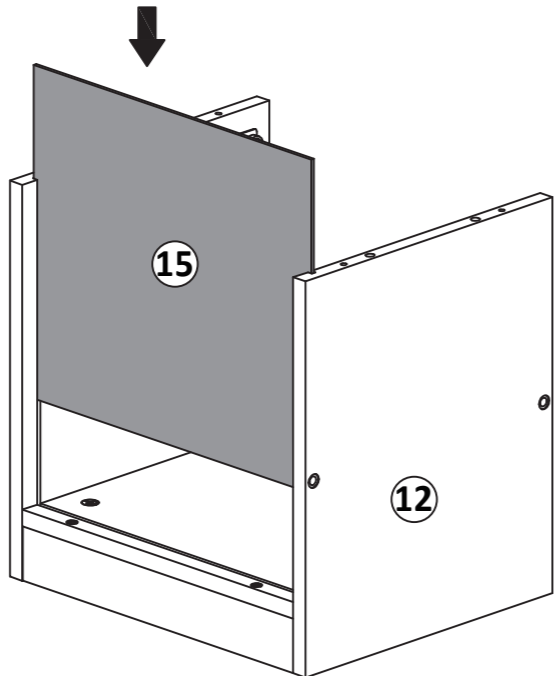

# INSTALLATIONSANLEITUNG

**Schritt 9**

①⑧ X 1  
 ①⑨ X 4  
 ①⑩ X 4

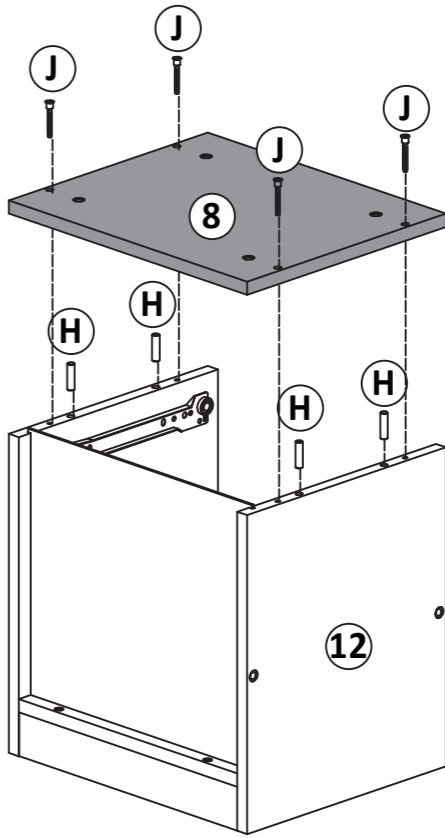

**Schritt 10**

①⑪ X 8  
 ①⑫ X 8

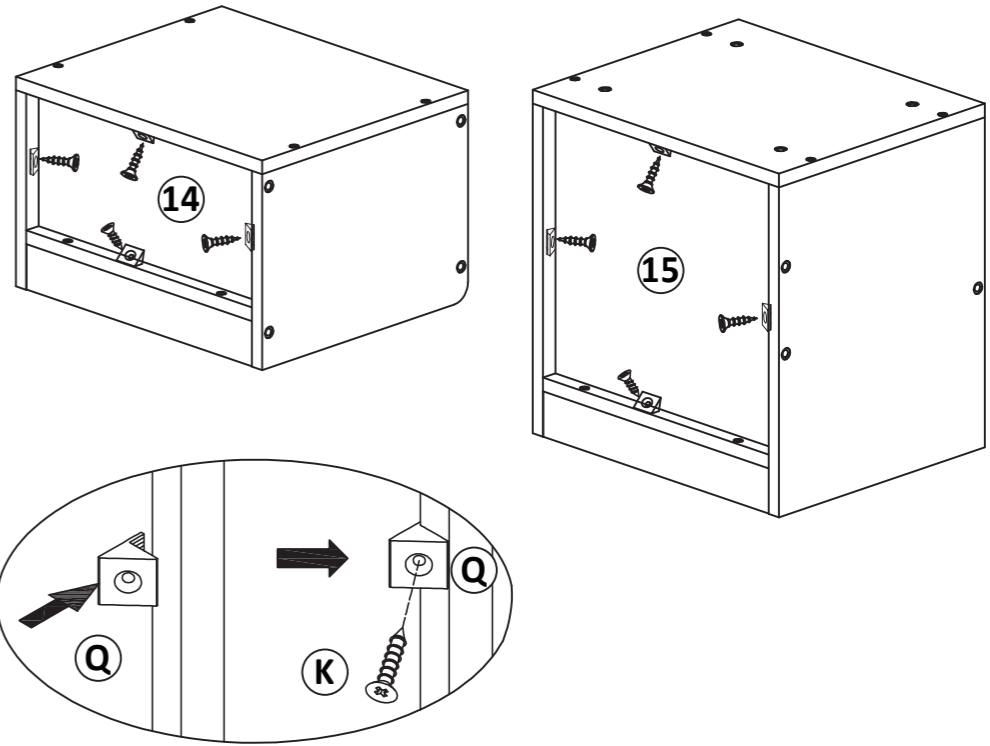

# INSTALLATIONSANLEITUNG

## Schritt 11



Ziehen Sie die Schrauben nicht fest, bis Schritt 13 fertig ist.

- ② X 2
- Ⓜ X 4

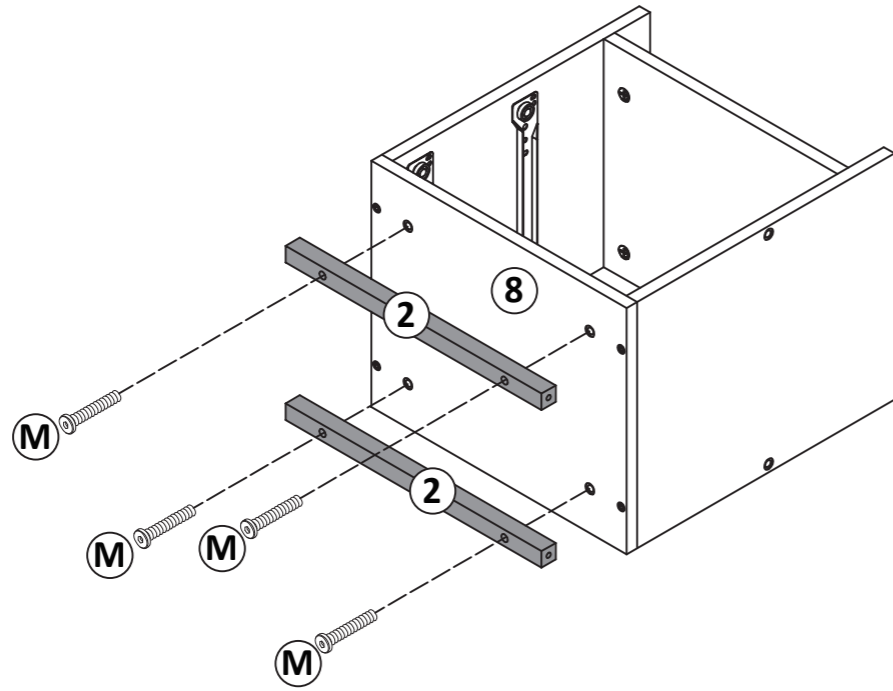

## Schritt 12



Ziehen Sie die Schrauben nicht fest, bis Schritt 13 fertig ist.

- ① X 1
- Ⓜ X 6
- Ⓝ X 2

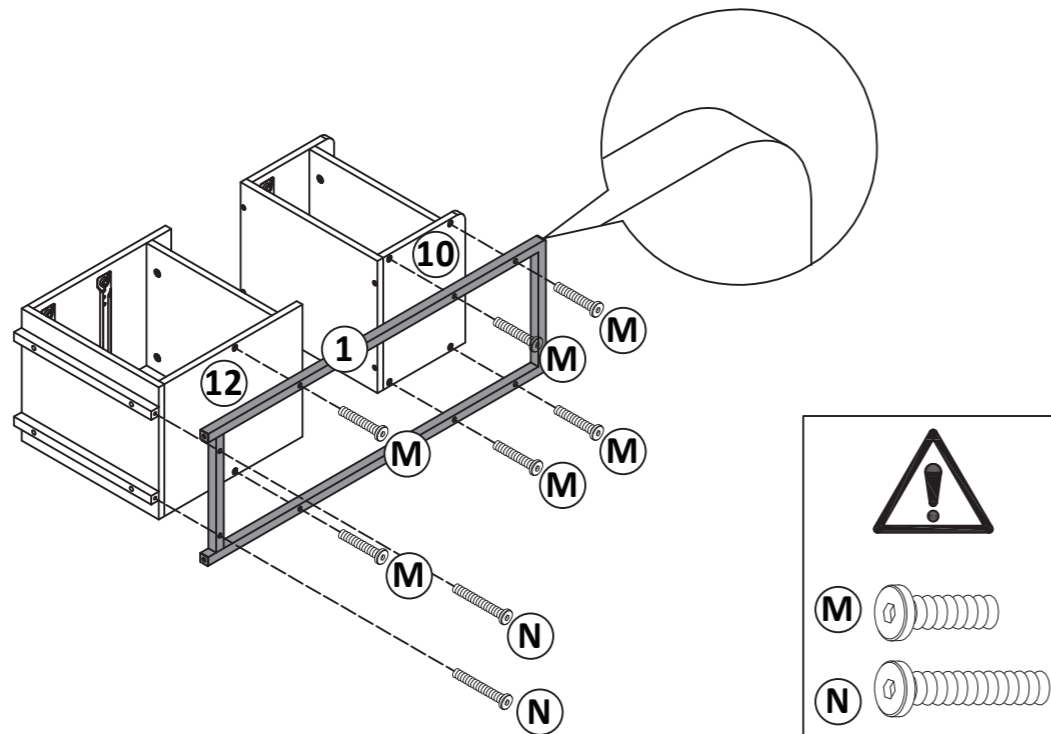

# INSTALLATIONSANLEITUNG

## Schritt 13



Ziehen Sie alle Schrauben fest.

- ① X 1
- Ⓜ X 6
- Ⓝ X 2

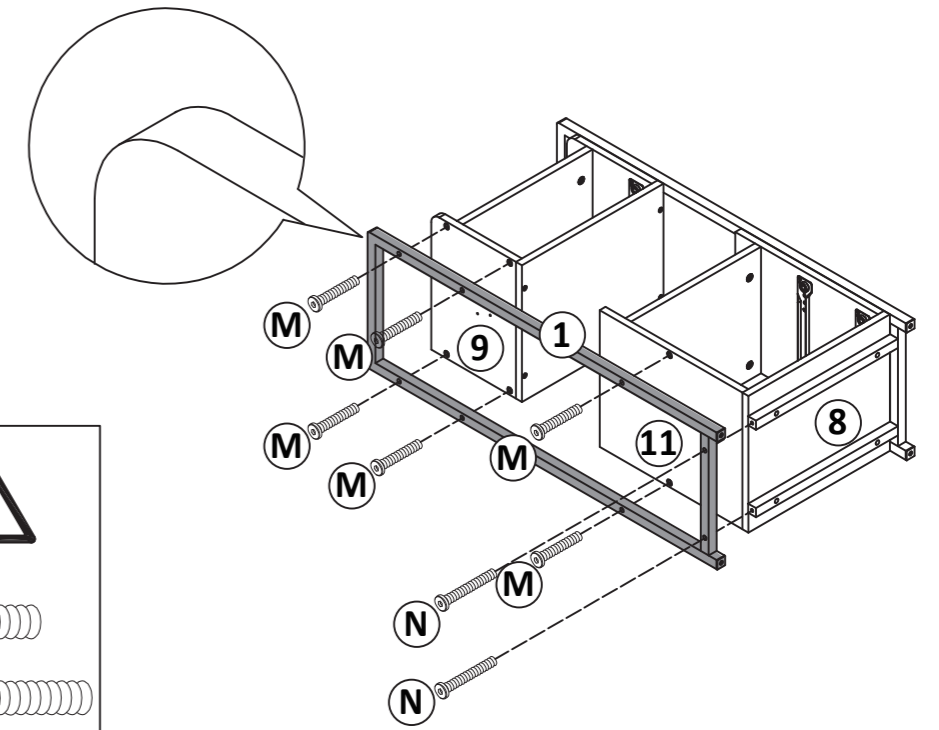
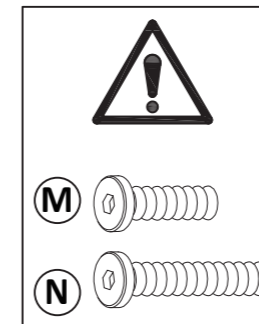

## Schritt 14

- Ⓛ X 3
- Ⓤ X 4
- Ⓥ X 1

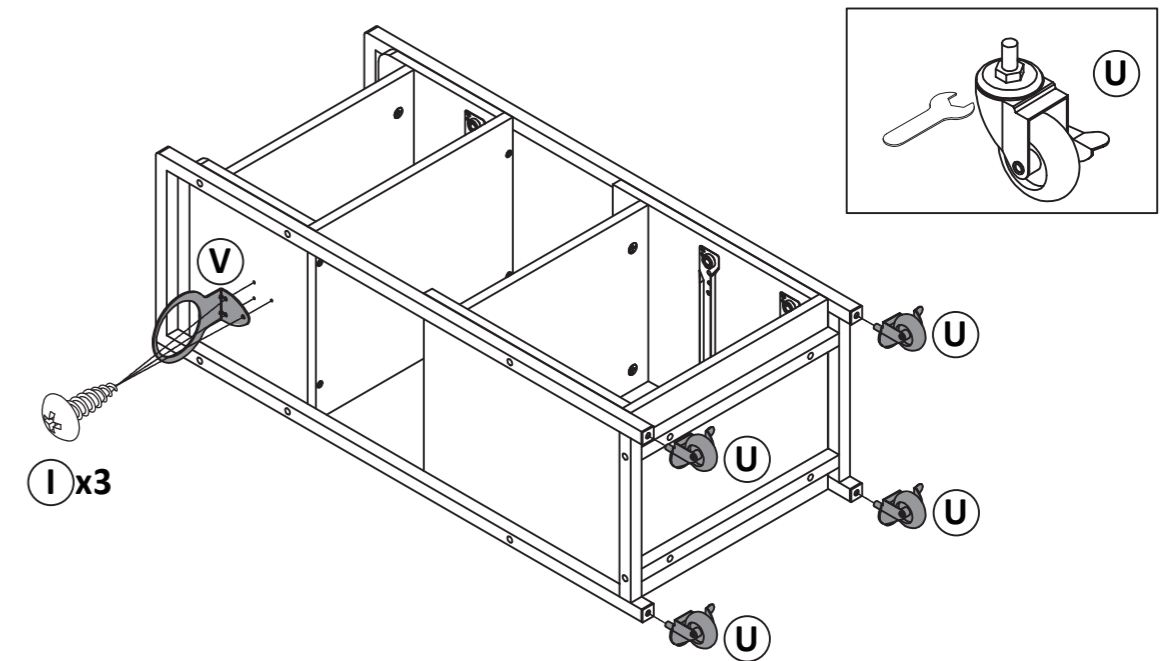



# INSTALLATIONSANLEITUNG

## Schritt 15

- ③ X 3
- ④ X 3
- ⑤ X 3
- ⑥ X 3
- ⑦ X 3
- ⑧ X 3
- ⑨ X 3
- ⑩ X 3
- ⑪ X 12
- ⑫ X 12
- ⑬ X 12
- ⑭ X 12

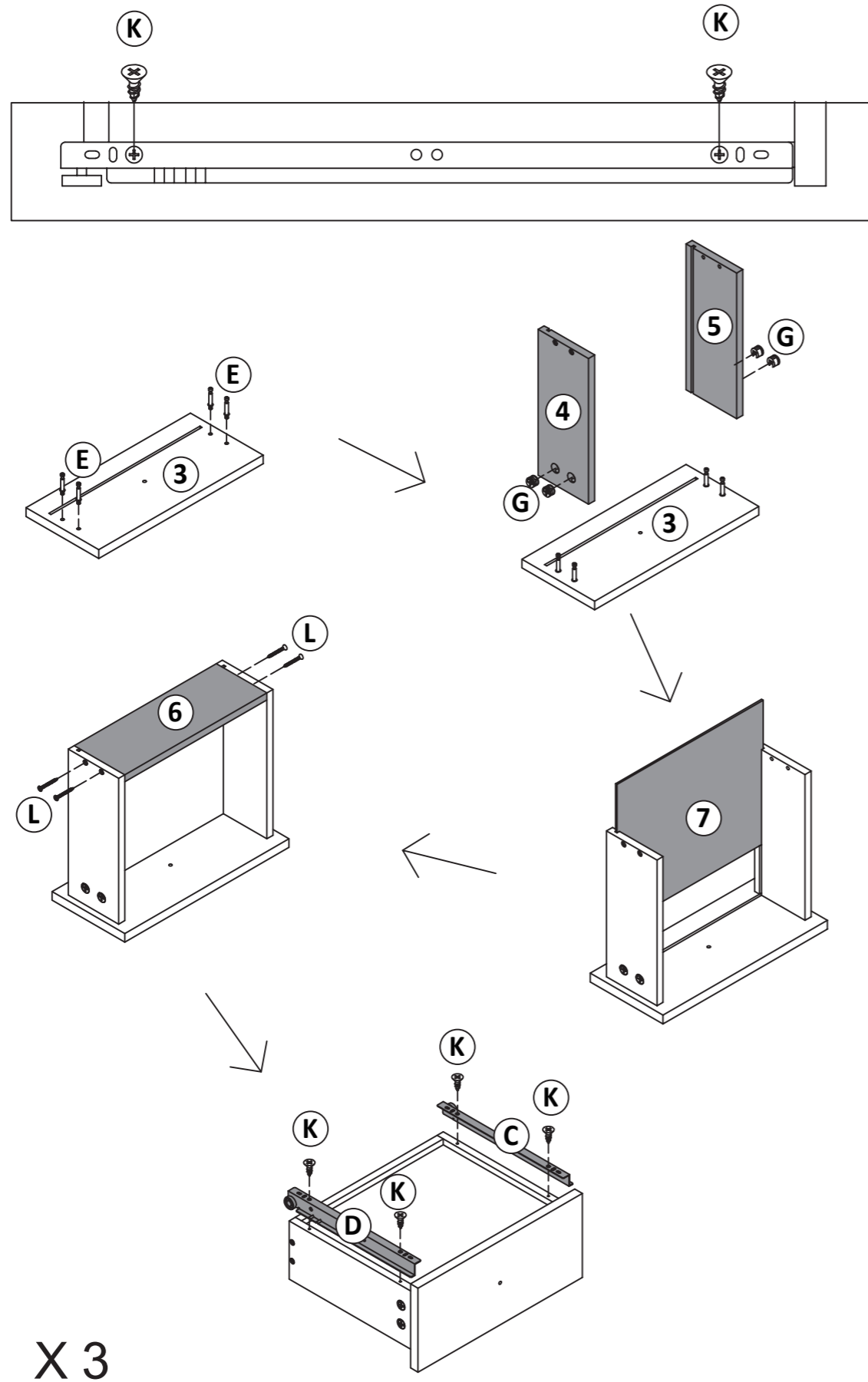

# INSTALLATIONSANLEITUNG

## Schritt 16

- ⊙ X 3
- Ⓟ X 3

X 3

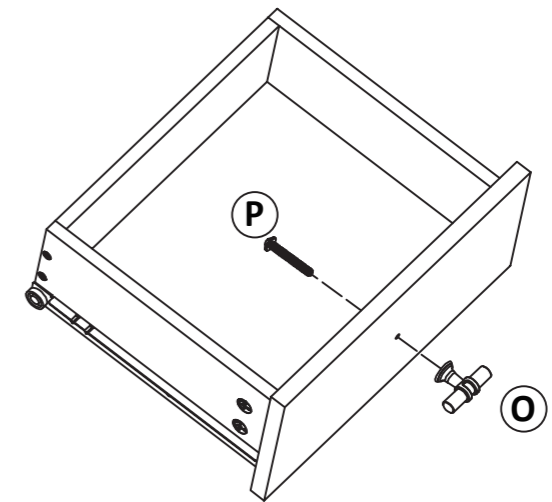

## Schritt 17

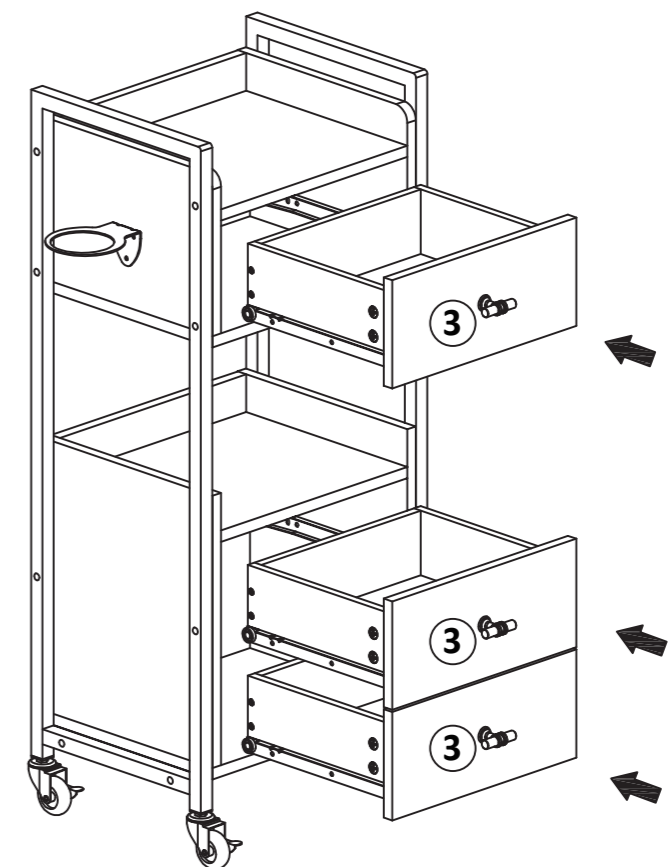

# MCOMBO KUNDENDIENST

Ist das Produkt vollständig erhalten? Ist die Installation und Nutzung reibungslos verlaufen?

Wenn Sie Fragen oder Anregungen haben, setzen Sie sich bitte rechtzeitig mit uns in Verbindung. Wir werden unser Bestes versuchen, um das Problem zu lösen.

Haben Sie spezielle Anforderungen an Größe, Farbe, Stil, Material oder andere Aspekte Ihres Produkts?

Zögern Sie nicht, uns zu kontaktieren, wir verstehen Ihre Bedürfnisse gerne und bieten Ihnen bessere Produkte.

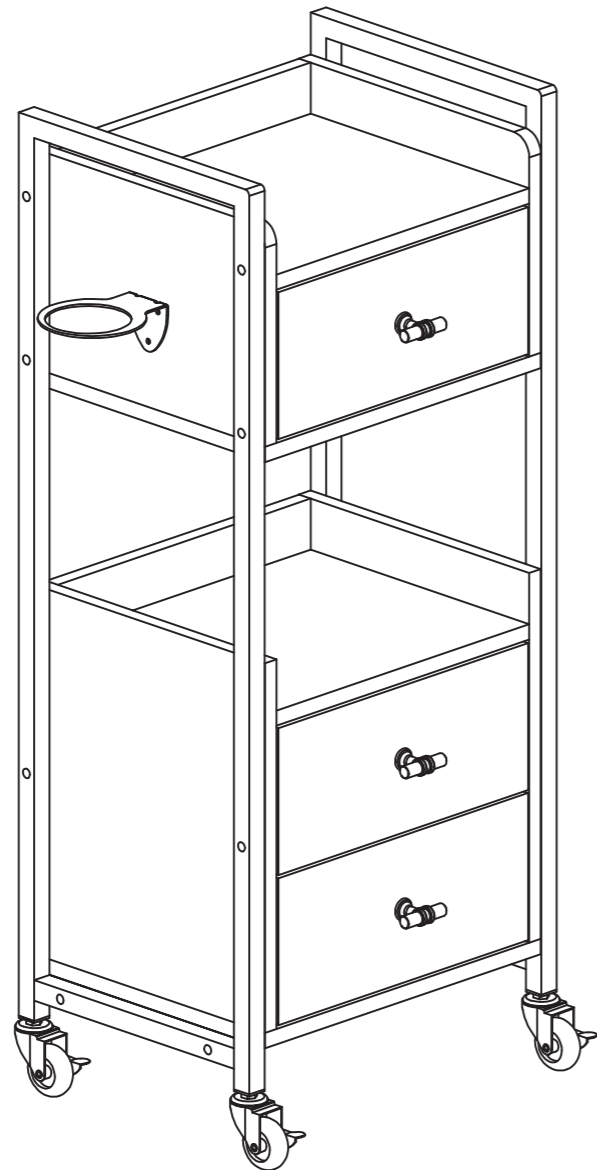

**Vielen Dank für Ihre Geduld bei der Montage!**

	0049-(0)21511561192
	pfillo.de@gmail.com (innerhalb 24h)
	Kreuzweg 60, 47809 Krefeld, Deutschland