

ASSEMBLY INSTRUCTIONS

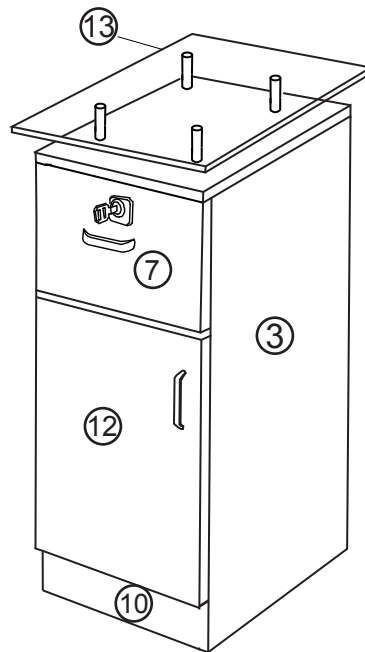
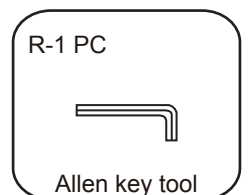
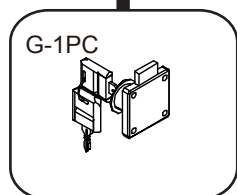
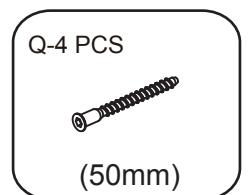
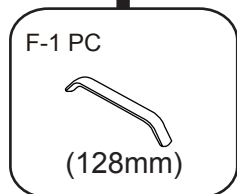
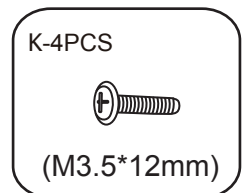
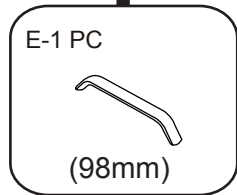
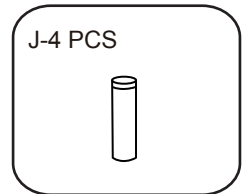
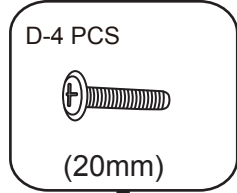
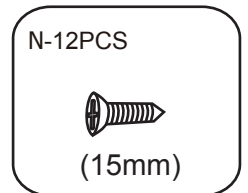
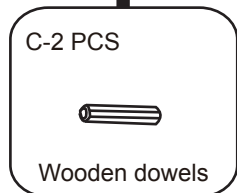
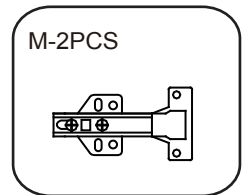
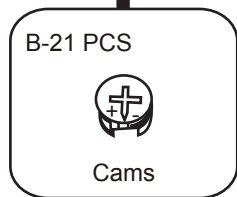
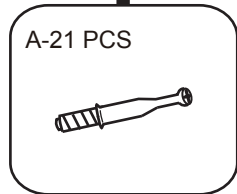
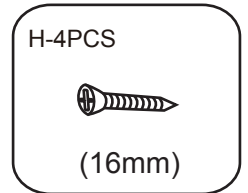
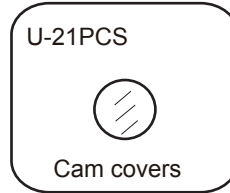
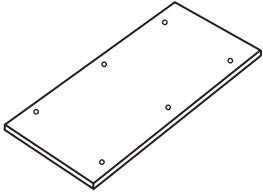

6154-3018

Additional tools required:
1 x cross-head screwdriver.

	714*415*16	1	①
----------------------------------------------------------------------------------	------------	---	---

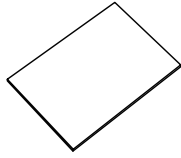
	368*294*3	1	⑧
------------------------------------------------------------------------------------	-----------	---	---

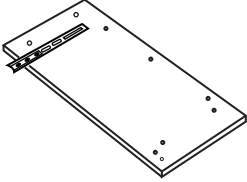
	714*330*16	1	②
-----------------------------------------------------------------------------------	------------	---	---

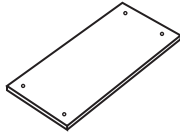
	415*311*16	1	⑨
------------------------------------------------------------------------------------	------------	---	---

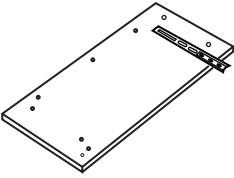
	714*330*16	1	③
----------------------------------------------------------------------------------	------------	---	---

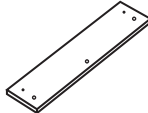
	415*80*16	1	⑩
------------------------------------------------------------------------------------	-----------	---	---

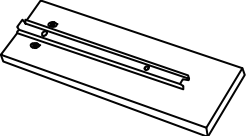
	300*90*16	1	④
-------------------------------------------------------------------------------------	-----------	---	---

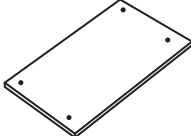
	449*349*16	1	⑪
--------------------------------------------------------------------------------------	------------	---	---

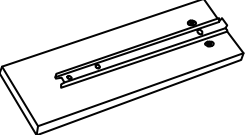
	300*90*16	1	⑤
-------------------------------------------------------------------------------------	-----------	---	---

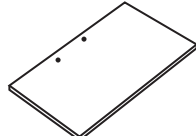
	446*475*16	1	⑫
--------------------------------------------------------------------------------------	------------	---	---

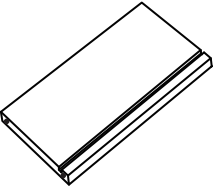
	358*90*16	1	⑥
-------------------------------------------------------------------------------------	-----------	---	---

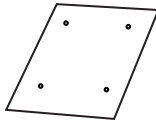
	446*349	1	⑬
--------------------------------------------------------------------------------------	---------	---	---

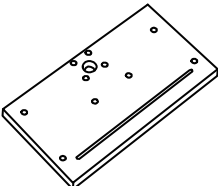
	446*150*16	1	⑦
-------------------------------------------------------------------------------------	------------	---	---

**DO NOT USE A POWER DRILL TO TIGHTEN THE SCREWS
 -TIGHTEN BY HAND WITH THE ALLEN KEY PROVIDED.
 Before use please check all fixings are tightened fully.**

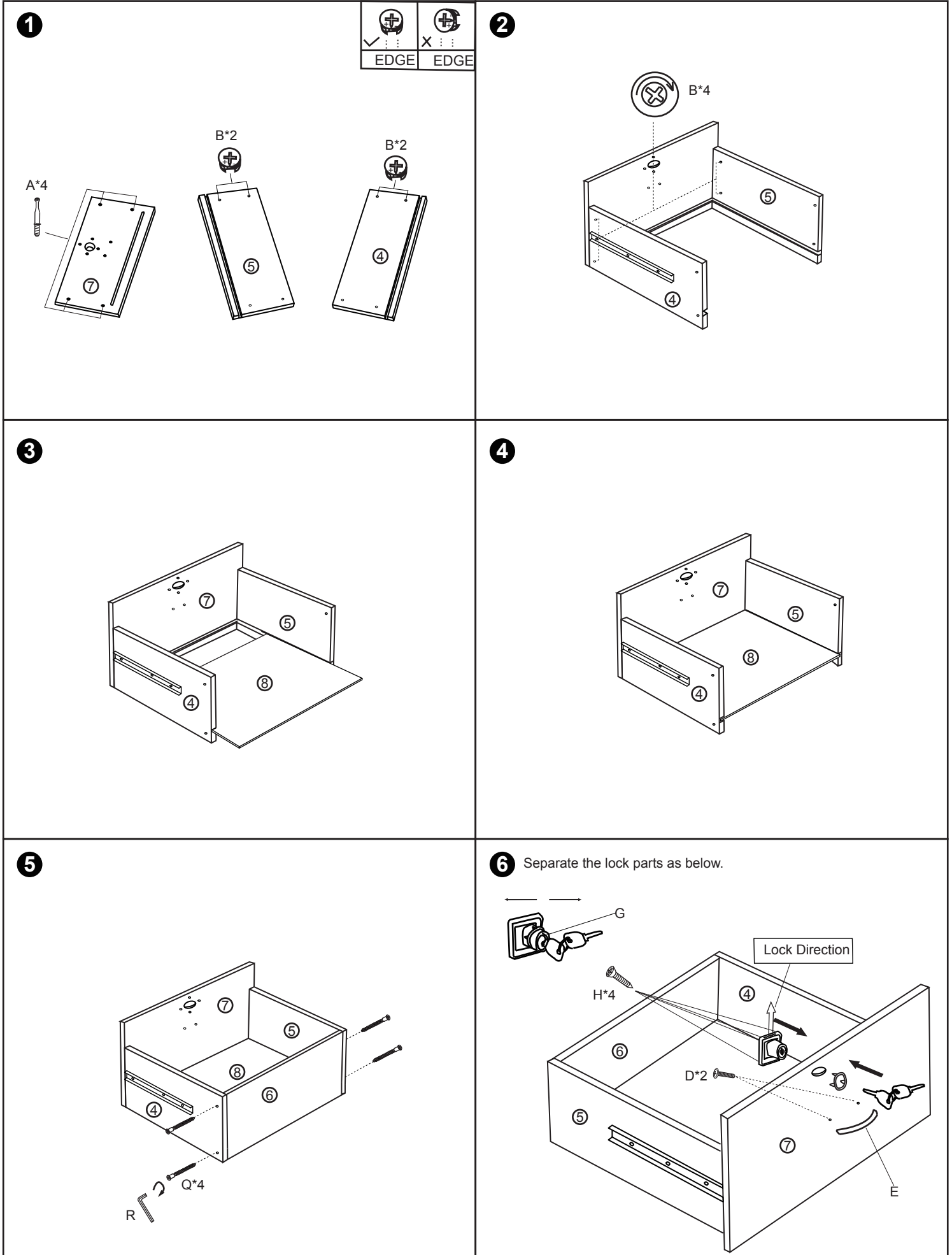

**DO NOT USE A POWER DRILL TO TIGHTEN THE SCREWS
 -TIGHTEN BY HAND WITH THE ALLEN KEY PROVIDED.
 Before use please check all fixings are tightened fully.**

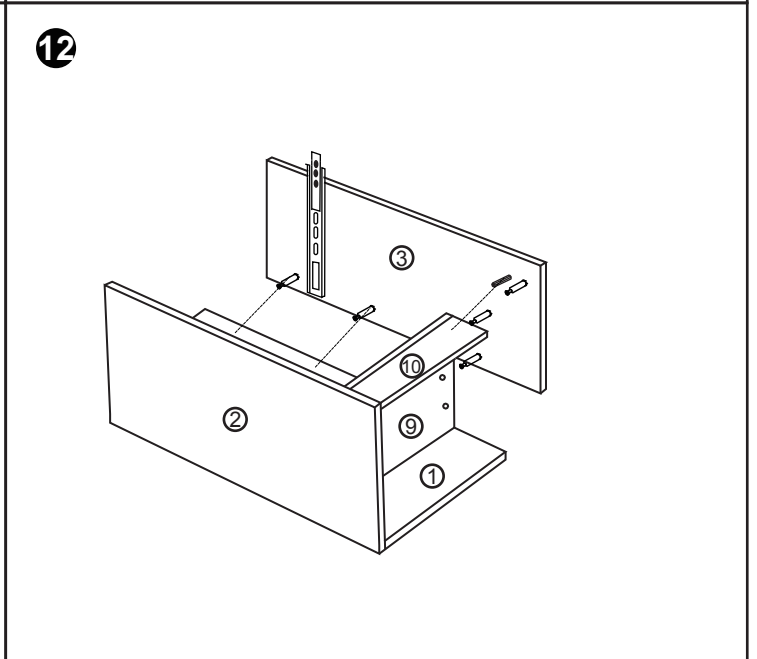
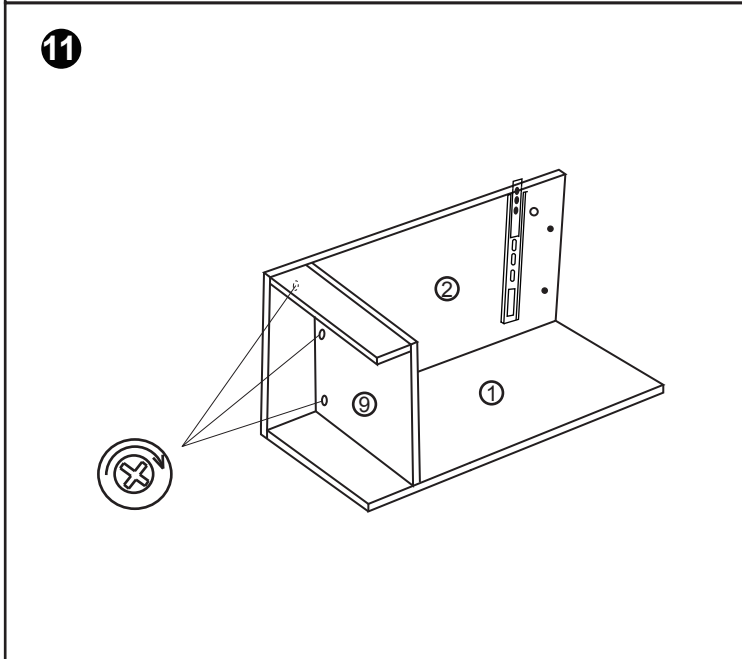
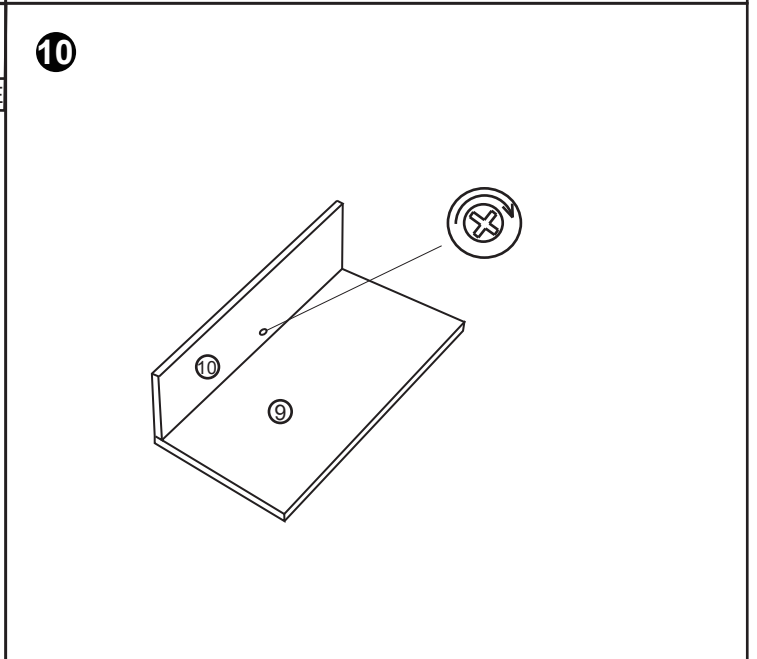
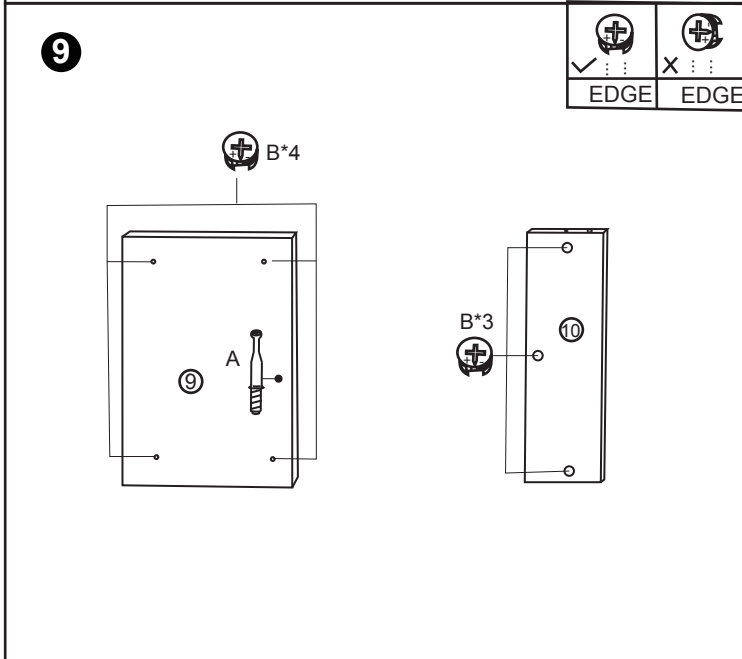
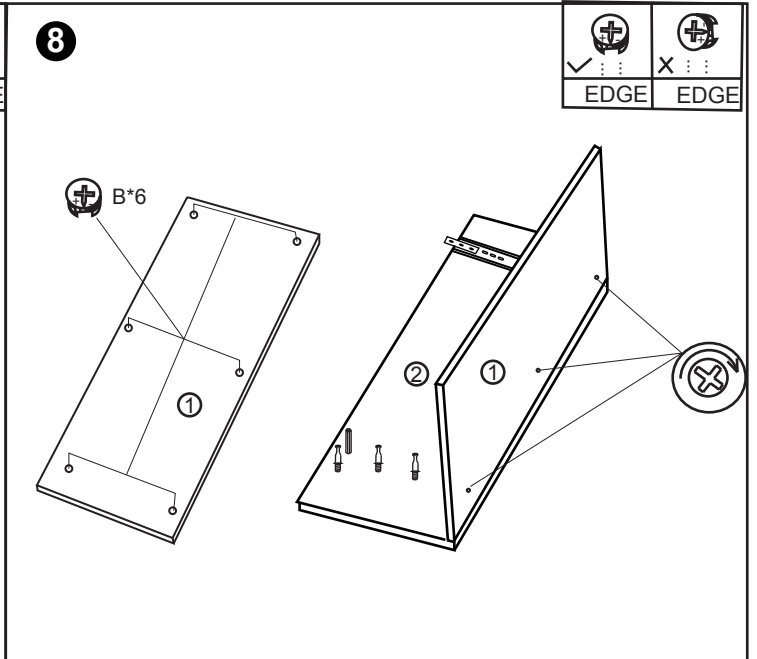
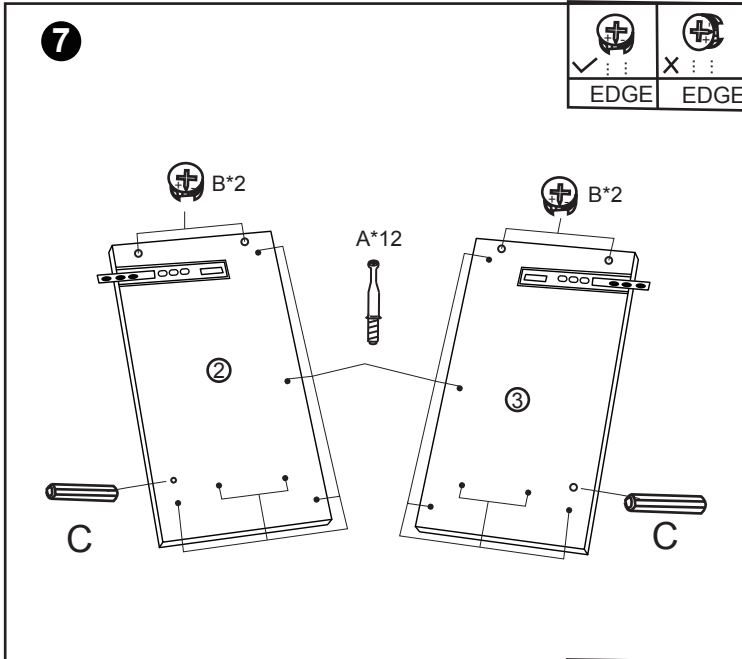

**DO NOT USE A POWER DRILL TO TIGHTEN THE SCREWS
 -TIGHTEN BY HAND WITH THE ALLEN KEY PROVIDED.
 Before use please check all fixings are tightened fully.**

13

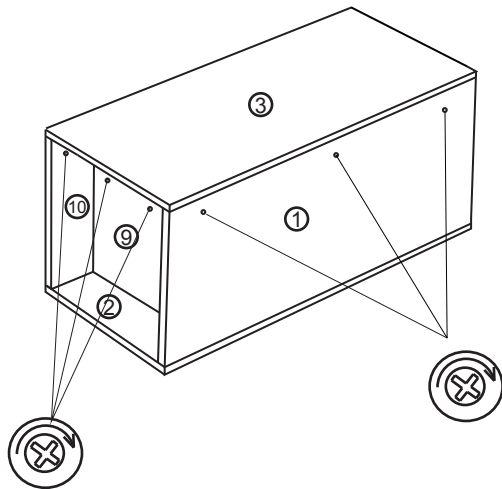

14

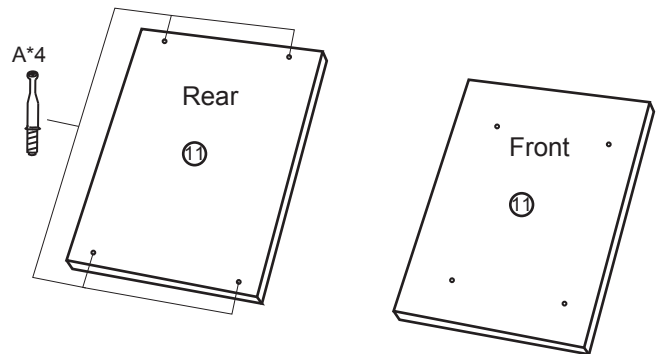

15

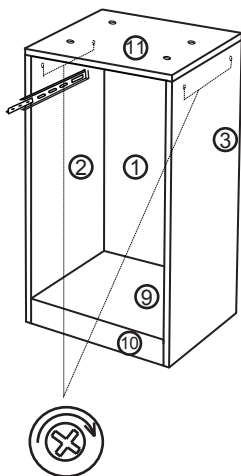

16

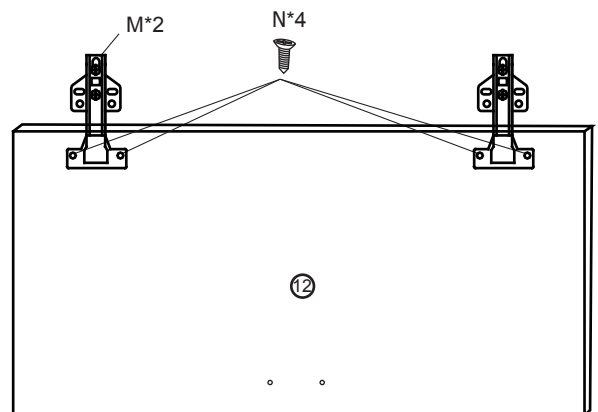

17

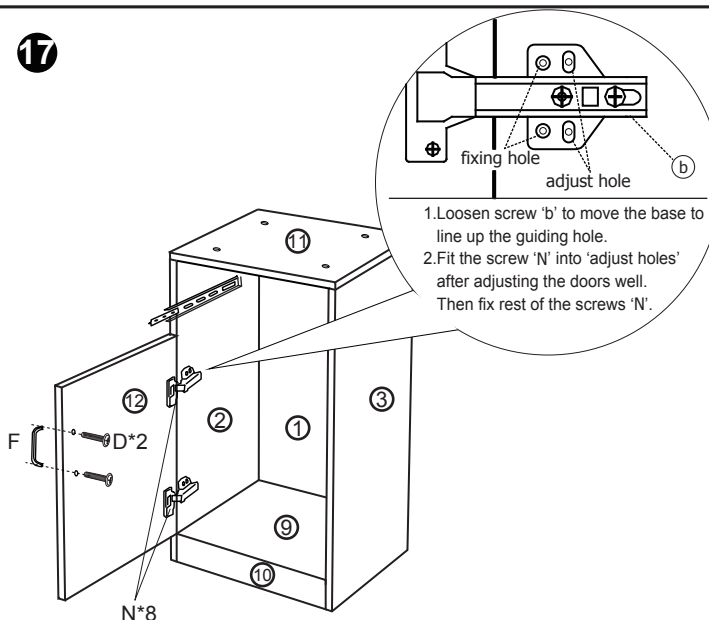

18

How to adjust the doors.

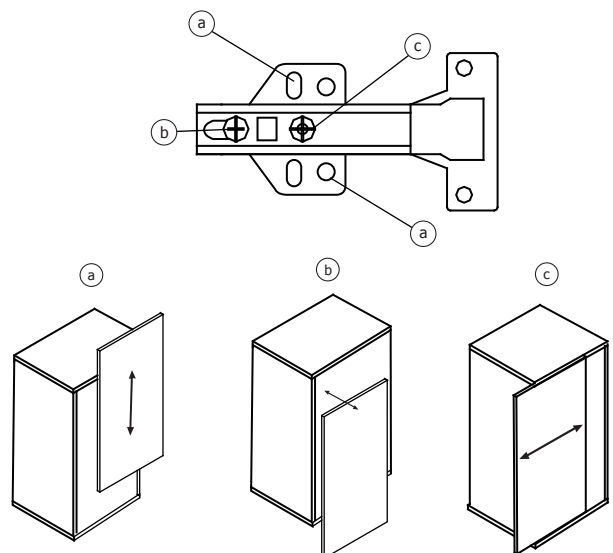

**DO NOT USE A POWER DRILL TO TIGHTEN THE SCREWS
-TIGHTEN BY HAND WITH THE ALLEN KEY PROVIDED.
Before use please check all fixings are tightened fully.**

19

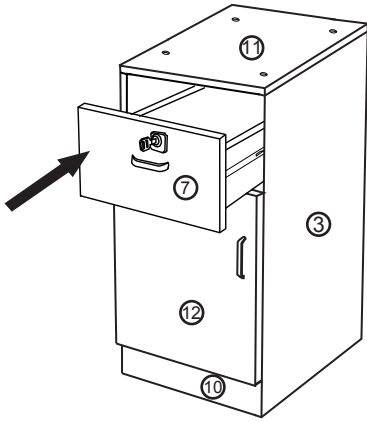

20 Separate the part "J" as below.

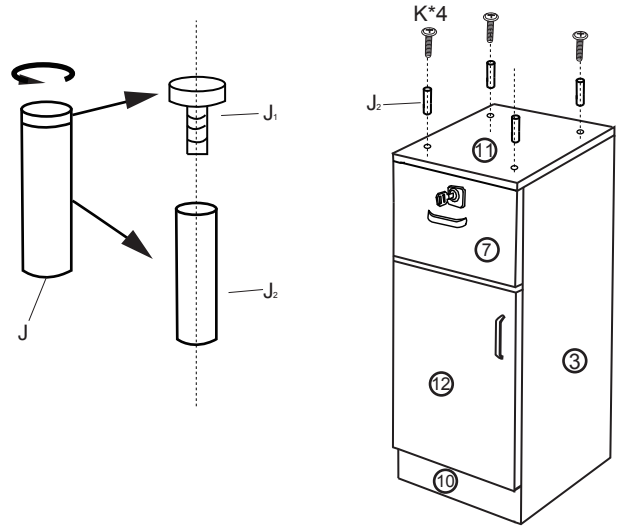

21

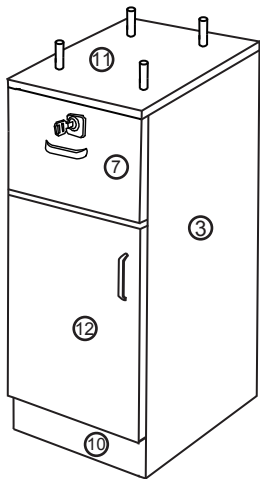

22

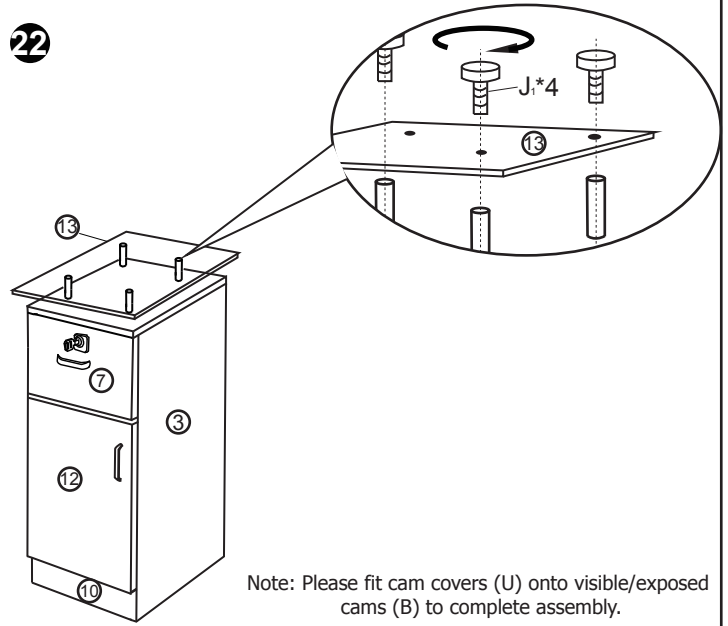

Note: Please fit cam covers (U) onto visible/exposed cams (B) to complete assembly.